



Gas Train Safeties

Safety Notice:

Burner safety circuits will always have a flame safeguard unit to control the gas valve's fuel supply to the burners. The purpose of the flame safeguard is to ignite and monitor the flame, and disable the gas valves if there is a loss of flame signal or a loss of the flame safeguard enable.

The normal sequence of burner ignition:

- ➔ Once, "Interlocks" are established, the flame safeguard enables the pilot solenoid and the ignitor.
- ➔ The flame safeguard then waits 7-10 seconds to detect a flame.
- ➔ If a flame is detected the flame safeguard will then open the main gas valves.

In this design, the "heat on" relay (CR6, below) receives coil voltage from the gas valve "open" circuit from the balances safeguard. This prevents voltage back-fed to the gas valves from circuits enabled by the "heat on" relay.

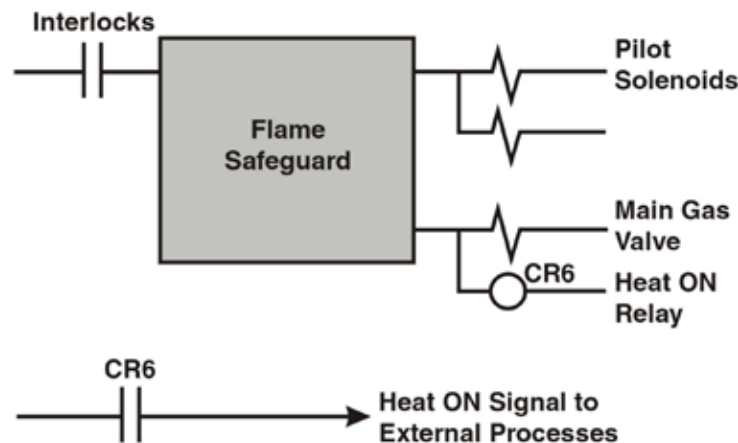

Warning: Do not wire the main gas valve output directly to external signals. For external signal, an isolation relay must be wired into the circuit. The isolation relay needs to be mounted close to the flame safeguard so that there is no risk of shorts in long wire runs.

Additional Notes:

Verify that the system has dual pilot solenoids. MEGTEC recommends two pilot solenoids are used. See *Upgrade Safety Bulletin UGB-001-Gas Train Design*

For further information, availability, please contact your nearest MEGTEC office by visiting www.megtec.com and click on parts and upgrades or email to info@megtec.com.